

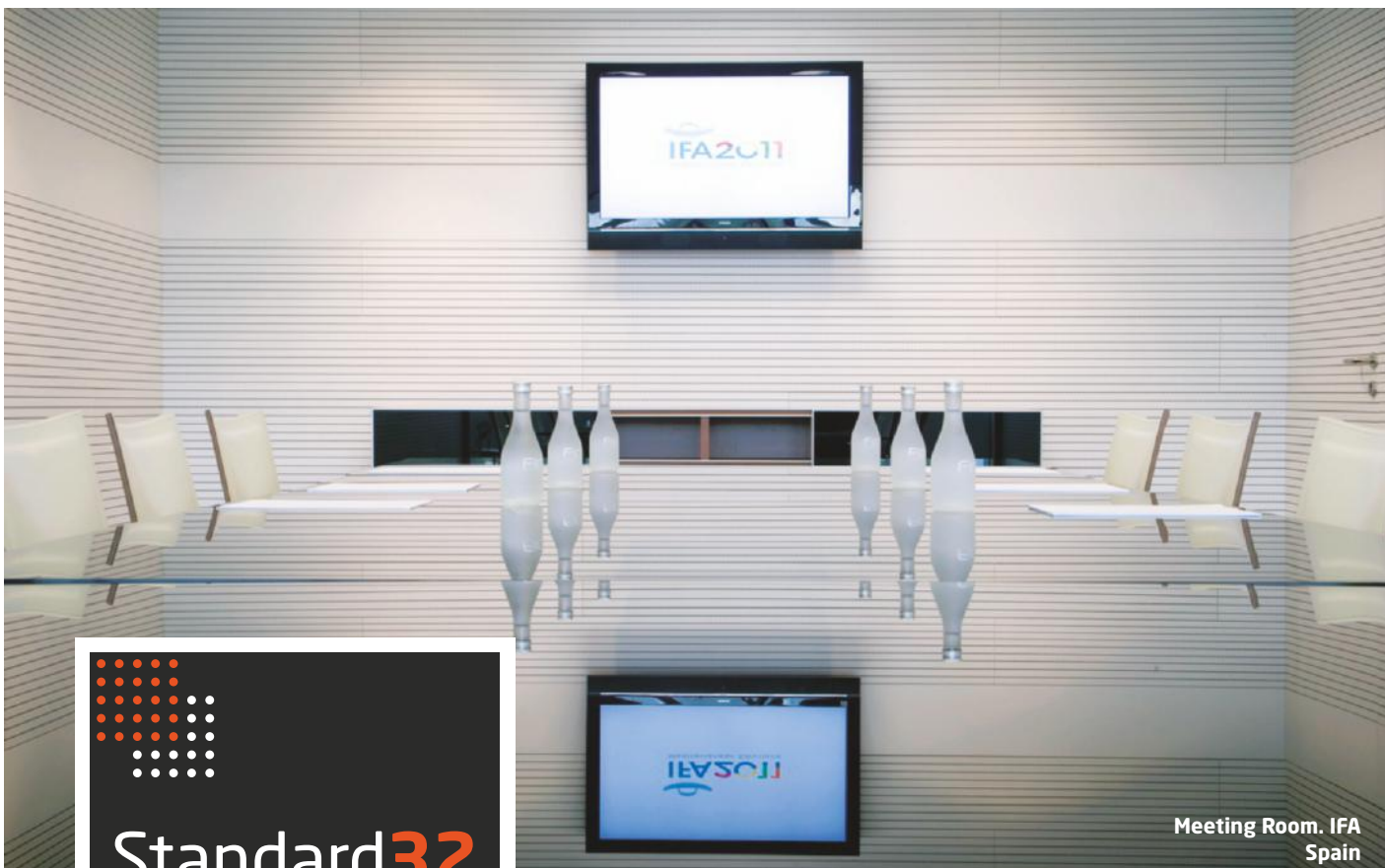

**Design and acoustic  
control integrated**





Meeting Room. IFA Spain



Ideacoustic's Standard 32 is a technical product of the highest level, intended for places requiring an enhanced acoustic ambience, whether big spaces like theaters or auditoriums, or smaller rooms, such as restaurants, shops or meeting areas.

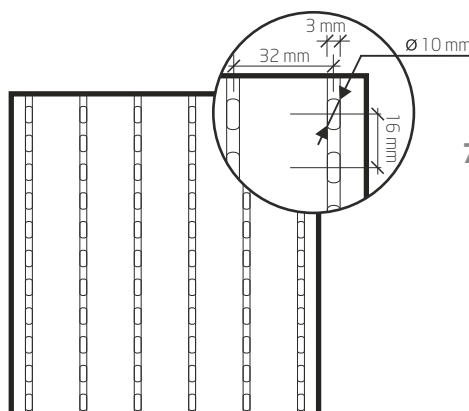

- Visible face: **grooves.**
- Reverse: **perforations.**

### Studied data

#### Dimensions

2430 x 160 x 16 mm  
7' 11-7/16" x 6-5/16" X 5/8"

#### Grooves

3 mm - 1/8"

#### Diameter

10 mm - 3/8"

#### Perforation percentage

7,55%

#### Perforation-available

2 mm, 3 mm and 4 mm  
1/16", 1/8" & 1/8"

### Absorption coefficient

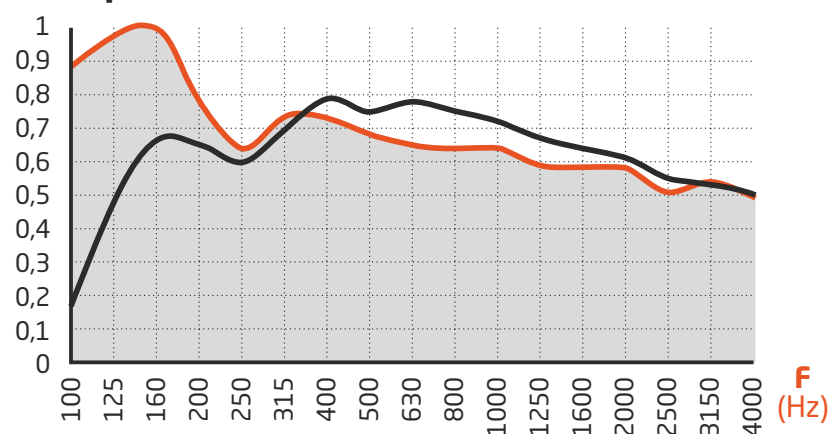

Medium acoustic absorption coefficient  $\alpha_m = 0,60$   
 $\alpha_m = 0,70$

Average acoustic absorption coefficient  $\alpha_w = 0,70$   
 $\alpha_w = 0,70$

Noise reduction coefficient **NRC = 0,65**  
**NRC = 0,65**

### test conditions

- A total of 21 cm (8-1/4") high in the Plenum + 4 cm (1-9/16") of rockwool.

- A total of 5 cm (2") high in the Plenum + 4 cm (1-9/16") of rockwool.

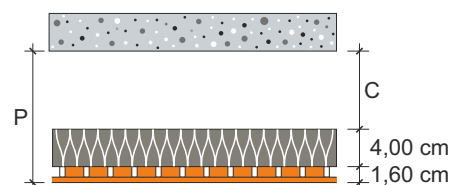





Great National Theater.  
Peru

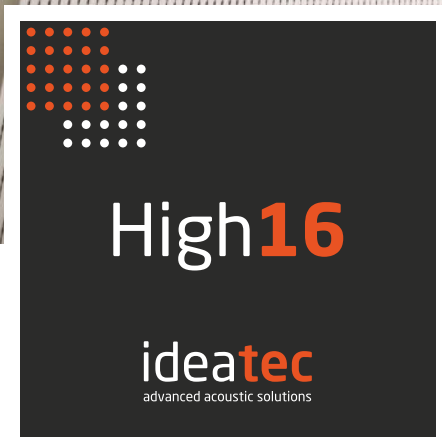

Ideacoustic's High 16 offers acoustic solutions for the most demanding spaces. Its acoustic performance within a wide range of frequencies makes it a reference product for the sector's professionals.

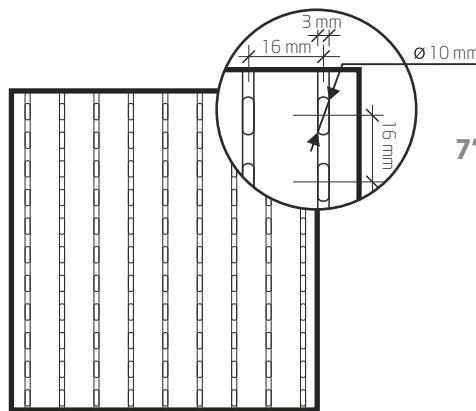

- Visible face: **grooves.**
- Reverse: **perforations.**

### Studied data

#### Dimensions

2430 x 160 x 16 mm  
7' 11-7/16" x 6-5/16" X 5/8"

#### Grooves

3 mm - 1/8"

#### Diameter

10 mm - 3/8"

#### Perforation percentage

11,47%

#### Perforation-available

2 mm, 3 mm and 4 mm  
1/16", 1/8" & 1/8"

### Absorption coefficient

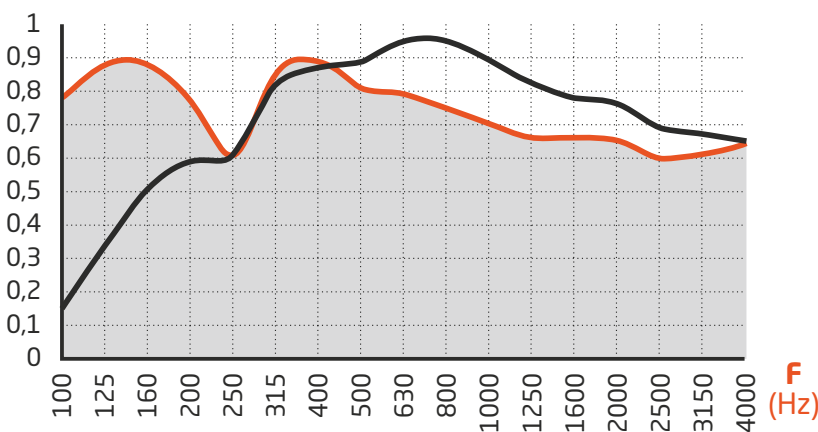

Medium acoustic absorption coefficient



$\alpha_m = 0,75$   
 $\alpha_m = 0,85$

Average acoustic absorption coefficient



$\alpha_w = 0,80$   
 $\alpha_w = 0,85$

Noise reduction coefficient



**NRC = 0,75**  
**NRC = 0,80**

### test conditions

- A total of 21 cm (8-1/4") high in the Plenum + 4 cm (1-9/16") of rockwool.

- A total of 5 cm (2") high in the Plenum + 4 cm (1-9/16") of rockwool.

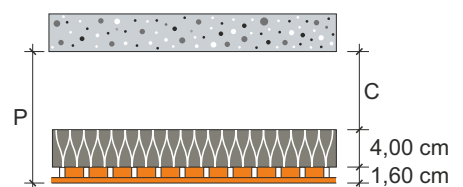

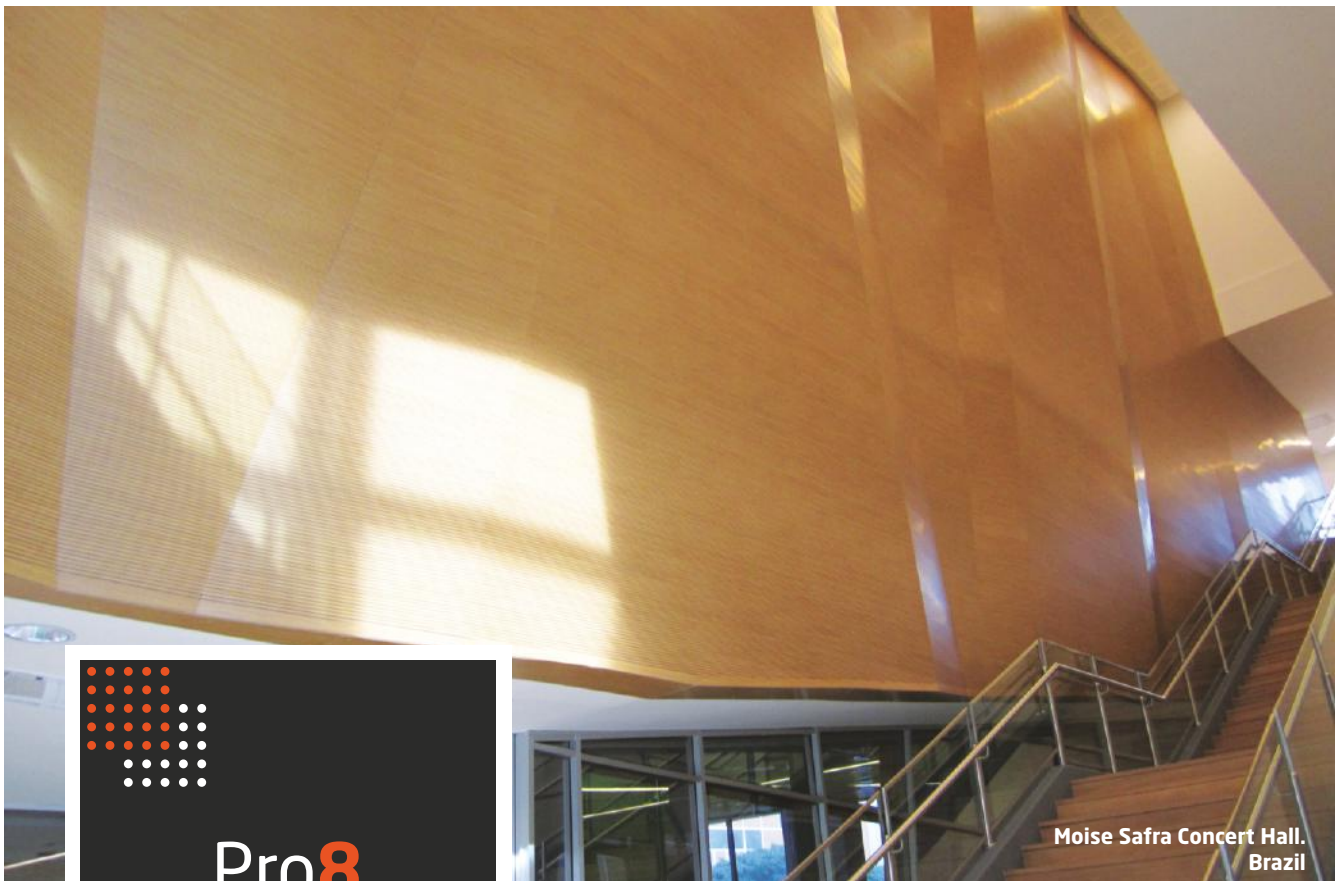

Moise Safra Concert Hall.  
Brazil



Ideacoustic's Pro 8 offers the most reliable acoustic solution thanks to its great absorption coefficient within the whole range of sound frequencies. This product is ideal for improving the acoustic comfort of spaces that need minimize the installation of sound absorptive materials, while satisfying the aesthetical requirements.

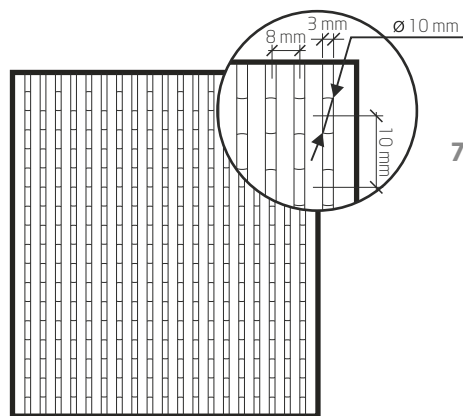

- Visible face: **grooves.**
- Reverse: **perforations.**

### Studied data

#### Dimensions

2430 x 160 x 16 mm  
7' 11-7/16" x 6-5/16" x 5/8"

#### Grooves

3 mm - 1/8"

#### Diameter

10 mm - 3/8"

#### Perforation percentage

19%

#### Perforation-available

2 mm, 3 mm  
1/16", 1/8"

### Absorption coefficient

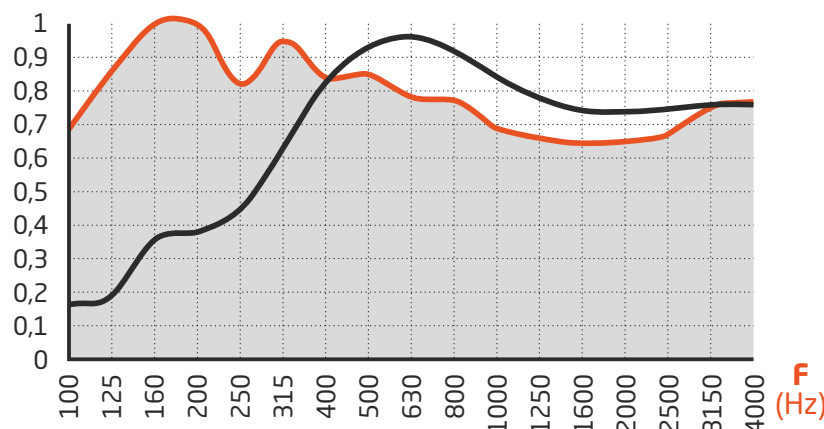

Medium  
acoustic  
absorption  
coefficient



$\alpha_m = 0,70$   
 $\alpha_m = 0,85$

Average  
acoustic  
absorption  
coefficient



$\alpha_w = 0,75$   
 $\alpha_w = 0,80$

Noise  
reduction  
coefficient



**NRC = 0,80**  
**NRC = 0,75**

### test conditions

- A total of 21 cm (8-1/4")  
high in the Plenum +  
4 cm (1-9/16") of rockwool.

- A total of 5 cm (2")  
high in the Plenum +  
4 cm (1-9/16") of rockwool.

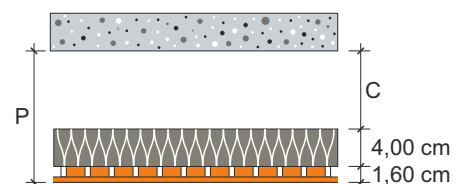





Music School.  
Monforte del Cid, Spain



**FLEX** solution, available in all **IDEATEC** models, offers acoustic conditioning solutions in curved surfaces, being concave, convex or undulated.

The installation includes special assembly systems with specific edges, meshes for complex 3D figures and other special layouts used in avant-garde architecture.

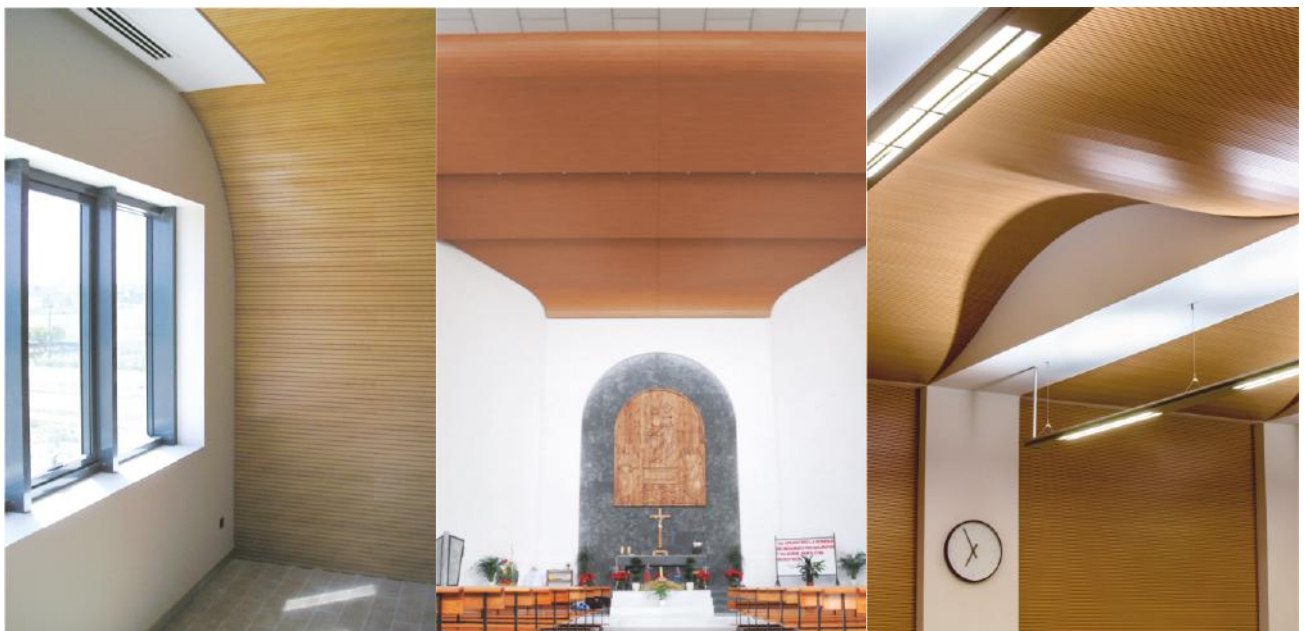

# Wood looking after sound

**IDEACUSTIC** product range gives an excellent acoustic control in high-end decoration spaces. Our panels for ceilings and walls are based in a slotted system with different drill widths and diameters, adapting to any technical or aesthetical need.

These options are often used in modern

architecture because they are able to integrate design and acoustic absorption. With **IDEACUSTIC** we get distinguishing terminations specially addressed to commercial spaces, auditoriums and any project where there is a need to satisfy the aesthetic layouts and to control the reverberation time.



## Support materials



MDF **Melamine** 16 mm (5/8")



MDF **Wood veneered** 16 mm (5/8")



**Plywood** 16 mm (5/8")



HPL **Phenolic compact** 16 mm (5/8")



**Special support materials:** Consult

**Phono-absorbent layer:** Black acoustic fabric attached to the back

**Dimensions:** | **Ceiling paneling:** 600/600 x 16 mm and 2430 x 160 x 16 mm  
(2' 2' x 5/8" and 7' 11-7/16" x 6-5/16" x 5/8")  
| **Wall paneling:** 2430 x 160 x 16 mm - (7' 11-7/16" x 6-5/16" x 5/8")

**Tolerance:** Width: +/- 1,5 mm (1/16") // Length: +/- 1,5 mm. (1/16") According to the EC Mark

## Installation:

Ceiling paneling



Wall panels



## Quality and project success guaranteed

We stand behind and guarantee all products we sell, thanks to our technology and the continuous supervision carried out by a large team of professionals. We strive to provide the best quality in all of our products and services.

Every production process is guaranteed by the **ISO 9001** and **ISO 14001** standards (referred to quality and Environment, respectively).

**IDEATEC** has the **PEFC**, Chain of Custody Certificate, which assures that we follow the principles established in the **Program for the Endorsement of Forest Certification (PEFC)**, a program that promotes sustainable forest management through forest certification. We only use wood from forests whose management is environmentally appropriate, economically viable and socially beneficial.

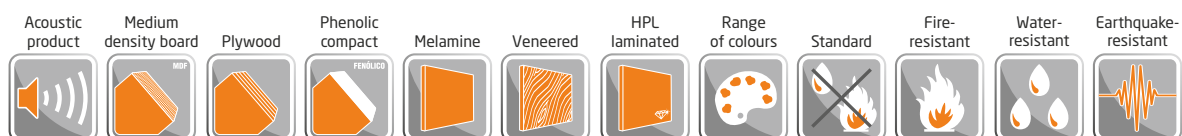



## Every option in finishings

Our wide range of finishings includes melamines -wooden or plain colors-, tints, lacquers and natural veneers. These options, applied to different base materials -MDF, plywood or phenolic compact-, have a final result of great quality in common. We also supply profile systems for ceilings and wall claddings for an easy installation. Adaptation to

the most demanding environments is possible thanks to the multiple combinations available with finishings, measurements, and distance between slots or drills.

All this, together with diffusers and ECOTEX fabric panels, allows us to offer highly effective acoustic and aesthetic solutions.

### Standard melamines



Maple



Cherry



Coral

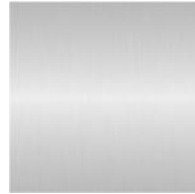

Silver



Pear



Wengue

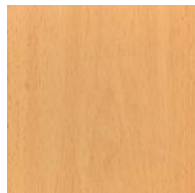

Beech

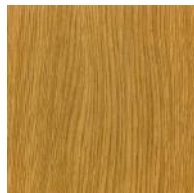

Oak

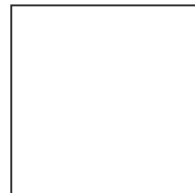

White



Cactus

### Standard wood veneer panels

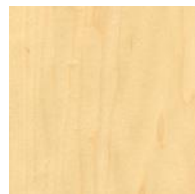

Maple

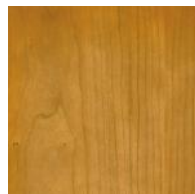

Cherry

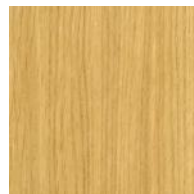

Oak

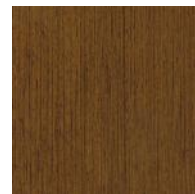

Wengue

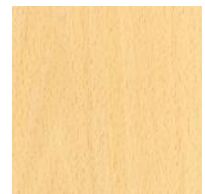

Beech



#### One-color melamine or hpl laminates

You can choose among more than 100 different colours.

#### Laquered panels

We have the necessary ability, technology and tools to supply our panels in any reference of PANTONE, RAL or NCS.

#### Mass-coloured mdf planks

Finally, we have a range of mass-coloured MDF planks with gives the tone of the desired colour with an innovation touch distinguishing it from the other systems.

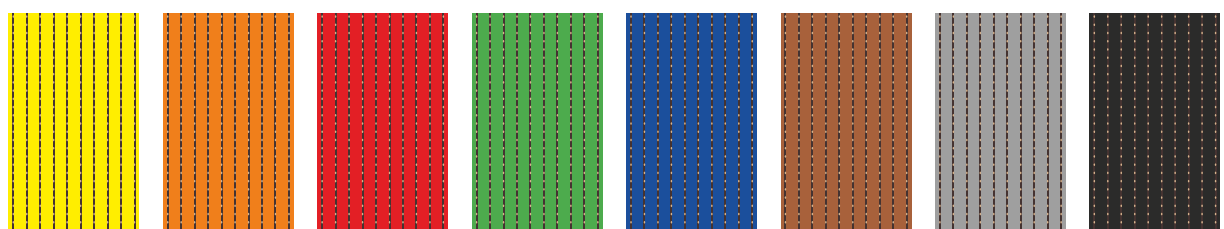



## Specialist in acoustic conditioning

**IDEATEC** is a world specialist in acoustic conditioning systems, based mainly in a natural element such as wood.

The panel systems for ceilings and walls, complemented with our diffusers and textile ECOTEX panels, achieve acoustic harmony in any interior space. Thanks to the versatility and variety of our range of acoustic solutions' it is possible to achieve the perfect combination between aesthetic and technical needs.

So appreciate and recognize acoustic engineers, architects, interior designers and building specialists.



2017.02.20 v



**Ideatec**

Pol. Ind. Santa Fe // Comuna di Carrara, 10  
03660 **Novelda** (Alicante) Spain

**T.** +34 965 609 046 // +34 965 609 162 // **F.** +34 965 609 163

[www.ideatec.es](http://www.ideatec.es) // [info@ideatec.es](mailto:info@ideatec.es)